



Panasonic

SUBMITTAL DATA SHEET

AHU Heat Pump System	
Location: _____	Approval: _____
Engineer: _____	Date: _____
Submitted to: _____	Construction: _____
Submitted by: _____	Unit #: _____
Reference: _____	Drawing #: _____

Set Model	
Indoor unit model	CS-HE30YAHK6
Outdoor unit model	CU-HE30YAHK6
AHRI Reference Number 212396494	
Certified	
AHR	
UL	
	



SYSTEM PERFORMANCE DATA			
Power supply			
Normal Operational Voltage	(V, Ph, Hz)	208/230V, 1Ph,	60Hz
Voltage Range	(V)		187-253
Electrical			
Minimum circuit ampacity (Outdoor)	(A)		23.0
Max.fuse (Outdoor)	(A)		35.0
Connection wiring		14AWG*2	Stranded, shielded
Cooling			
Capacity	(Btu/h)	30000(10000-33600)	
Power Input	(W)	3060(370-3360)	
Current	(A)	13.2(2.9-15)	
SEER2	(Btu/W)		16.2
EER2	(Btu/W)		9.8
Heating			
Capacity	(Btu/h)	33000(11500-37000)	
Power Input	(W)	2930(550-3250)	
Current	(A)	13.3(4.0-14.6)	
HSPF2-4	(Btu/W)		8.9
HSPF2-5	(Btu/W)		7.0
COP	W/W		3.30
Heat at 17F(H32)	(Btu/h)		21000
Heat at 5F(H42)	(Btu/h)		24000
COP at 5F(H42)	W/W		1.77

REFRIGERANT PIPE DATA		
Throttle type	Indoor unit	EEV for cooling
	Outdoor unit	EEV for heating
Design pressure	(PSIG)	550/340
Refrigerant Type		R410A
Refrigerant charge	oz	134.04
Refrigerant precharge	(ft)	25.0
	(m)	7.5
Additional charge for each ft	(oz/ft)	0.69
Additional charge for each m	(g/m)	65.0
Liquid side/ Gas side(indoor)	(inch)	3/8" / 3/4"
	(mm)	9.52/19
Liquid side/ Gas side(outdoor)	(inch)	3/8" / 3/4"
	(mm)	9.52/19
Max. pipe length	(ft)	164.0
	(m)	50.0
Max. difference in level	(ft)	82.0
	(m)	25.0
Connection method		Flared
Indoor(cooling)	(Deg. °F)	60~90
	(Deg. °C)	16~32
Indoor(heating)	(Deg. °F)	32~86
	(Deg. °C)	0~30
Outdoor(cooling)	(Deg. °F)	5~122
	(Deg. °C)	-15~50
Outdoor(heating)	(Deg. °F)	-22~75
	(Deg. °C)	-30~24

INDOOR UNIT DATA			
Indoor fan motor			
Model			ZKFD-375-8-1-1
Qty			1
Input	(W)		/
Output	(W)		/
RLA	(A)		3.5
Speed(Hi/Mi/Lo)	(r/min)		/
Air flow & Noise level			
Indoor air flow (Hi/Med/Lo) (No duct)	(CFM)	1088.24/894.12/805.88/711.76	
Indoor noise level (Hi/Med/Lo)	[dB(A)]	42/40.5/36.5	
Dehumidification	(LH)		3.41
Indoor unit			
Dimension (WxDxH)	(inch)	21.02x21.02x49.02	
	(mm)	534x534x1245	
Packing(WxDxH)	(inch)	26.57x24.41x52.56	
	(mm)	675x620x1335	
Net/Gross weight	(lbs.)	129.19/155.64	
	(kg)	58.6/70.6	
Accessories			
Adaptor for welding(3/4")	Qty		1
Adaptor for welding(3/8")	Qty		1

OUTDOOR UNIT DATA			
Compressor			
Type			ROTARY
Model			KTF310D43UMT
Brand			GMCC
Capacity	(Btu/h)		34154
Input	(W)		2765
Rated current (RLA)	(A)		16.5
Refrigerant oil/oil charge	(ml)		VG74/1000
Outdoor fan motor			
Model			ZKFN-120-8-2
Qty			1
Input	(W)		150.0
Output	(W)		120
RLA	(A)		1.4
Speed	(r/min)		950/900/500
Air flow & Noise level			
Outdoor air flow (Max.)	(CFM)		3000
Outdoor noise level	[dB(A)]		60.5
Outdoor unit			
Dimension (WxDxH)	(inch)	37.24x16.14x31.89	
	(mm)	946x410x810	
Packing (WxDxH)	(inch)	42.91x19.69x34.84	
	(mm)	1090x500x885	
Net/ Gross weight	(lbs.)	159.83/169.75	
	(kg)	72.5/77	
Accessories			
Adaptor for welding(3/4")	Qty		1
Adaptor for welding(3/8")	Qty		1

Indoor unit dimension

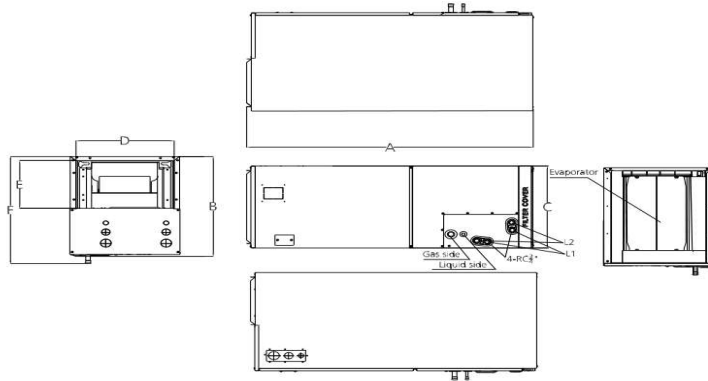

Model	Unit	Dimensions(mm)						Drain hole	
		A	B	C	D	E	F	L1	L2
18k-24k	mm	1143	534	445	400	260	585	Main drain	Overflow drain
	inch	45	21	17-1/2	15-3/4	10-1/4	23		
30k-48k	mm	1245	534	534	490	260	585		
	inch	49	21	21	19-5/16	10-1/4	23		
60k	mm	1346	534	622	580	260	585		
	inch	53	21	24-1/2	22-7/8	10-1/4	23		

Outdoor unit dimension

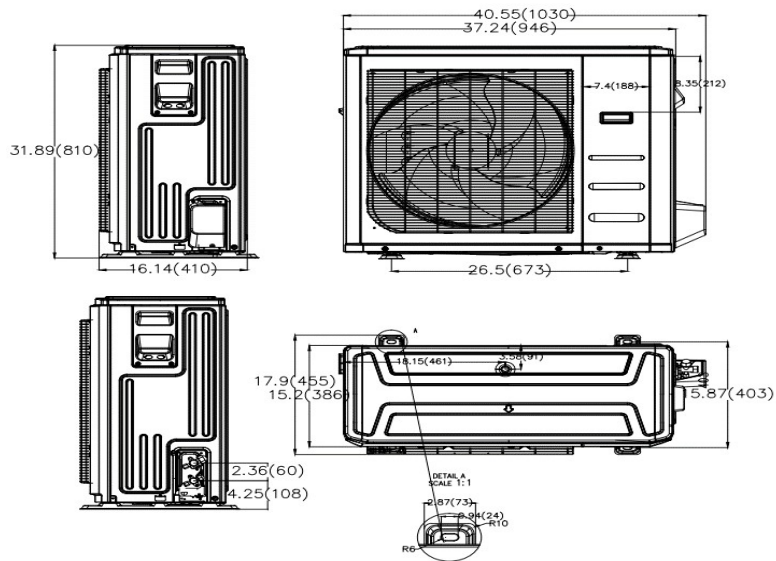

30K

