

Panasonic

Two Speed
Cordless
Drill & Driver

Operating Instructions

Model No: EY6220

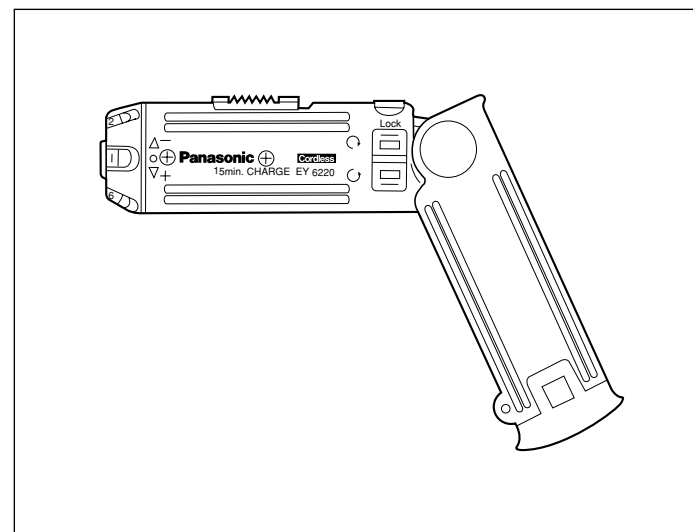

PANASONIC CONSUMER ELECTRONICS COMPANY
One Panasonic Way, Secaucus, New Jersey 07094

⚠ IMPORTANT

This manual contains safety information. Read manual completely before first using this product.

SAVE THESE INSTRUCTIONS

Parts and Controls

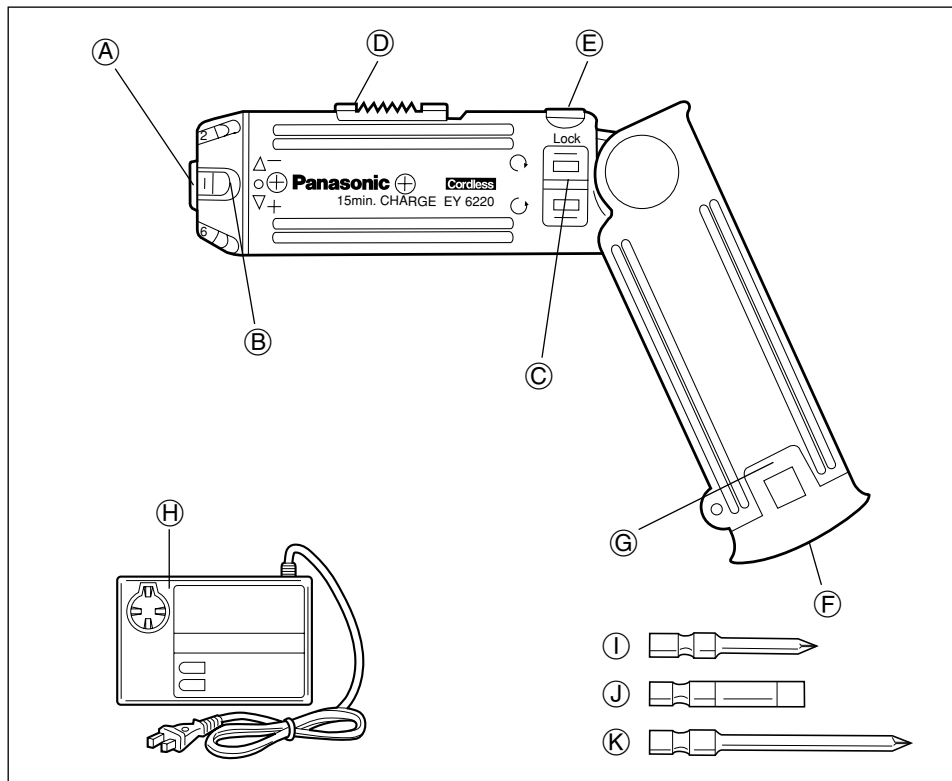

(A)	Hexagonal bit holder	(F)	Battery pack (EY9021)
(B)	Clutch handle	(G)	Battery pack release button
(C)	Main switch	(H)	Battery charger (EY0225)
(D)	Speed selector switch	(I)	#1 Philips bit
(E)	Main switch lock	(J)	Slotted head bit
		(K)	#2 Philips bit

I. GENERAL SAFETY RULES

⚠ WARNING! Read all instructions

Failure to follow all instructions listed below may result in electric shock, fire and/or serious injury. The term "power tool" in all of the warnings listed below refers to your mains operated (corded) power tool and battery operated (cordless) power tool.

SAVE THESE INSTRUCTIONS

Work Area Safety

- 1) **Keep work area clean and well lit.** Cluttered or dark areas invite accidents.
- 2) **Do not operate power tools in explosive atmospheres, such as in the presence of flammable liquids, gases or dust.** Power tools create sparks which may ignite the dust or fumes.
- 3) **Keep children and bystanders away while operating a power tool.** Distractions can cause you to lose control.

Electrical Safety

- 1) **Power tool plugs must match the outlet. Never modify the plug in any way. Do not use any adapter plugs with earthed (grounded) power tools.** Unmodified plugs and matching outlets will reduce risk of electric shock.
- 2) **Avoid body contact with earthed or grounded surfaces such as pipes, radiators, ranges and refrigerators.** There is an increased risk of electric shock if your body is earthed or grounded.
- 3) **Do not expose power tools to rain or wet conditions.** Water entering a power tool will increase the risk of electric shock.
- 4) **Do not abuse the cord. Never use the cord for carrying, pulling or unplugging the power tool. Keep cord away from heat, oil, sharp edges or moving parts.** Damaged or entangled cords increase the risk of electric shock.
- 5) **When operating a power tool outdoors, use an extension cord suitable for outdoor use.** Use of a cord suitable for outdoor use reduces the risk of electric shock.

Personal Safety

- 1) **Stay alert, watch what you are doing and use common sense when operating a power tool. Do not use a power tool while you are tired or under the influence of drugs, alcohol or medication.** A moment of inattention while operating power tools may result in personal injury.
- 2) **Use safety equipment. Always wear eye protection.** Safety equipment such as dust mask, non-skid safety shoes, hard hat, or hearing protection used for appropriate conditions will reduce personal injuries.
- 3) **Avoid accidental starting. Ensure the switch is in the off position before plugging in.** Carrying power tools with your finger on the switch or plugging in the power tools that have the switch on invites accidents.
- 4) **Remove any adjusting key or wrench before turning the power tool on.** A wrench or a key left attached to a rotating part of the power tool may result in personal injury.
- 5) **Do not overreach. Keep proper footing and balance at all times.** This enables better control of the power tool in unexpected situations.
- 6) **Dress properly. Do not wear loose clothing or jewellery. Keep your hair, clothing and gloves away from moving parts.** Loose clothes, jewellery or long hair can be caught in moving parts.
- 7) **If devices are provided for the connection of dust extraction and collection facilities, ensure these are connected and properly used.** Use of these devices can reduce dust related hazards.

Power Tool Use and Care

- 1) **Do not force the power tool. Use the correct power tool for your application.** The correct power tool will do the job better and safer at the rate for which it was designed.
- 2) **Do not use the power tool if the switch does not turn it on and off.** Any power tool that cannot be controlled with the switch is dangerous and must be repaired.

- 3) **Disconnect the plug from the power source and/or the battery pack from the power tool before making any adjustments, changing accessories, or storing power tools.**

Such preventive safety measures reduce the risk of starting the power tool accidentally.

- 4) **Store idle power tools out of the reach of children and do not allow persons unfamiliar with the power tool or these instructions to operate the power tool.** Power tools are dangerous in the hands of untrained users.
- 5) **Maintain power tools. Check for misalignment or binding of moving parts, breakage of parts and any other condition that may affect the power tools operation. If damaged, have the power tool repaired before use.**

Many accidents are caused by poorly maintained power tools.

- 6) **Keep cutting tools sharp and clean.** Properly maintained cutting tools with sharp cutting edges are less likely to bind and are easier to control.
- 7) **Use the power tool, accessories and tool bits etc. in accordance with these instructions and in the manner intended for the particular type of power tool, taking into account the working conditions and the work to be performed.**

Use of the power tool for operations different from those intended could result in a hazardous situation.

Battery Tool Use and Care

- 1) **Ensure the switch is in the off position before inserting battery pack.** Inserting battery pack into power tools that have the switch on invites accidents.
- 2) **Recharge only with the charger specified by the manufacturer.** A charger that is suitable for one type of battery pack may create a risk of fire when used with another battery pack.
- 3) **Use power tools only with specifically designated battery packs.** Use of any other battery packs may create a risk of injury and fire.
- 4) **When battery pack is not in use, keep it away from other metal objects like paper clips, coins, keys, nails, screws, or other small metal objects that can make a connection from one terminal to another.**

- Shorting the battery terminals together may cause burns, or a fire.
- 5) **Under abusive conditions, liquid may be ejected from battery; avoid contact. If contact accidentally occurs, flush with water. If liquid contacts eyes, additionally seek medical help.** Liquid ejected from the battery may cause irritation or burns.

Service

- 1) **Have your power tool serviced by a qualified repair person using only identical replacement parts.** This will ensure that the safety of power tool is maintained.

II. SPECIFIC SAFETY RULES

- 1) **Wear ear protectors when using the tool for extended periods.** Prolonged exposure to high intensity noise can cause hearing loss.
- 2) Be aware that this tool is always in an operating condition, since it does not have to be plugged into an electrical outlet.
- 3) **Hold power tools by insulated gripping surfaces when performing an operation where the cutting tool may contact hidden wiring.** Contact with a "live" wire will make exposed metal parts of the tool "live" and shock the operator.
- 4) If the bit becomes jammed, immediately turn the main switch off to prevent an overload which can damage the battery pack or motor. Use reverse motion to loosen jammed bits.
- 5) Do not touch the rotating parts to avoid injury.
- 6) Do not use the tool continuously for a long period of time. Stop using the tool from time to time to avoid temperature rise and heat overload of the motor.
- 7) Do not drop the tool.

Symbol	Meaning
V	Volts
---	Direct current
n ₀	No load speed
... min ⁻¹	Revolutions or reciprocations per minutes
Ah	Electrical capacity of battery pack

⚠ WARNING!

Some dust created by power sanding, sawing, grinding, drilling, and other construction activities contains chemicals known to the State of California to cause cancer, birth defects or other reproductive harm. Some examples of these chemicals are:

- Lead from lead-based paints
- Crystalline silica from bricks and cement and other masonry products
- Arsenic and chromium from chemically-treated lumber.

To reduce your exposure to these chemicals: work in a well ventilated area, and work with approved safety equipment, such as dust masks that are specially designed to filter out microscopic particles.

III. FOR BATTERY CHARGER & BATTERY PACK

Important Safety Instructions

- 1) **SAVE THESE INSTRUCTIONS** -This manual contains important safety and operating instructions for battery charger EY0225.
- 2) Before using battery charger, read all instructions and cautionary markings on battery charger, battery pack, and product using battery pack.
- 3) **CAUTION** -To reduce the risk of injury, charge only Panasonic Battery Pack as shown in last page. Other types of batteries may burst causing personal injury and damage.
- 4) Do not expose charger and battery pack to rain or snow.
- 5) To reduce risk of damaging the electric plug and cord, pull by plug rather than

cord when disconnecting charger.

- 6) Make sure cord is located so that it will not be stepped on, tripped over, or otherwise subjected to damage or stress.
- 7) An extension cord should not be used unless absolutely necessary. Use of improper extension cord could result in a risk of fire and electric shock. If extension cord must be used, make sure that:
 - a. pins on plug of extension cord are the same number, size and shape as those of plug on charger.
 - b. extension cord is properly wired and in good electrical condition.
 - c. wire size is large enough for ampere rating of charger as specified below.

RECOMMENDED MINIMUM AWG SIZE OF EXTENSION CORDS FOR BATTERY CHARGERS			
AC Input Rating.	Amperes	AWG Size of Cord	
Equal to or greater than	But less than	Length of Cord, Feet	
0	2	25	50 100 150
		18	18 18 16

- 8) Do not operate charger with damaged cord or plug-replace them immediately.
- 9) Do not operate charger if it has received a sharp blow, been dropped, or otherwise damaged in any way; take it to a qualified service personnel.
- 10) Do not disassemble charger; take it to a qualified service personnel when service or repair is required. Incorrect reassembly may result in a risk of electric shock or fire.
- 11) To reduce the risk of electric shock, unplug charger from outlet before attempting any maintenance or cleaning.
- 12) The charger and battery pack are specifically designed to work together. Do not attempt to charge any other cordless tool or battery pack with this charger.
- 13) Do not attempt to charge the battery pack with any other charger.
- 14) Do not attempt to disassemble the battery pack housing.
- 15) Do not store the tool and battery pack in locations where the temperature may reach or exceed 50°C (122°F) (such as a metal tool shed, or a car in the summer), which can lead to deterioration of the storage battery.

- 16) Do not charge battery pack when the temperature is BELOW 0°C (32°F) or ABOVE 40°C (104°F). This is very important in order to maintain optimal condition of the battery pack.
- 17) Do not incinerate the battery pack. It can explode in a fire.
- 18) Avoid dangerous environment. Do not use charger in damp or wet locations.
- 19) The charger is designed to operate on standard household electrical power only. Do not attempt to use it on any other voltage!
- 20) Do not abuse cord. Never carry charger by cord or yank it to disconnect from outlet. Keep cord away from heat, oil and sharp edges.
- 21) Charge the battery pack in a well ventilated place, do not cover the charger and battery pack with a cloth, etc., while charging.
- 22) Use of an attachment not recommended may result in a risk of fire, electric shock, or personal injury.
- 23) Do not short the battery pack. A battery short can cause a large current flow, over heating and create the risk of fire or personal injury.
- 24) NOTE: If the supply cord of this appliance is damaged, it must only be replaced by a repair shop authorized by the manufacturer, because special purpose tools are required.
- 25) TO REDUCE THE RISK OF ELECTRIC SHOCK, THIS APPLIANCE HAS A POLARIZED PLUG (ONE BLADE IS WIDER THAN THE OTHER). This plug will fit in a polarized outlet only one way. If the plug does not fit fully in the outlet, reverse the plug. If it still does not fit, contact a qualified electrician to install the proper outlet. Do not change the plug in any way.

IMPORTANT NOTICE

PLEASE READ THIS ENTIRE NOTICE BEFORE OPERATING YOUR NEW PANASONIC CORDLESS POWER TOOL!

PANASONIC'S CHARGING SYSTEM UTILIZES A QUALITY HIGH TEMPERATURE NICKEL CADMIUM BATTERY PACK IN CONJUNCTION WITH OUR SELF-DIAGNOSTIC UNIVERSAL INVERTER CHARGER.

THIS HIGH TEMPERATURE NICKEL CADMIUM BATTERY PACK REQUIRES A "BREAK-IN PERIOD" TO REACH *MAXIMUM OPERATING CAPACITY*. THE "BREAK-IN PERIOD" IS ACCOMPLISHED DURING NORMAL USAGE DURING THE FIRST 6-8 CHARGE AND DISCHARGE CYCLES OF THE BATTERY PACK.

AFTER THE "BREAK-IN PERIOD" IS COMPLETED, THE BATTERY PACK WILL MAINTAIN *MAXIMUM OPERATING CAPACITY* THROUGHOUT THE NORMAL LIFE OF THE BATTERY PACK.

ASSEMBLY & OPERATION

A Hexagonal driving shaft

NOTE: When attaching or removing bit, be sure to set the main switch lock at the lock position. Select the suitable bit and lightly push it into the hexagonal driving shaft of the main unit.

Hexagonal driving shaft

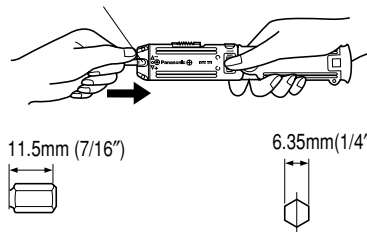

B Clutch handle

When using the tool for driving screws into soft material or for terminal screws, etc., there is the possibility of damaging the material or threads if the torque is too high. To compensate for this, the clutch torque may be adjusted by turning the clutch handle to the required setting.

Clutch position 1 is the minimum and the clutch torque increases with positions 2, 3, 4, and 5. When the device is set at position 6, the clutch will not slip and the connection to the motor will be direct.

CAUTION: If the battery pack loses its power during usage, the clutch may not slip even at positions 4 or 5, if this occurs, recharge the battery pack.

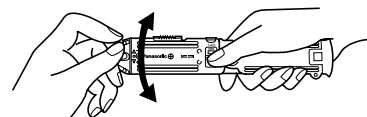

Bit locking function

With the switch at off, the bit is locked in place, and the tool can be used as a manual screw-driver.

There will be a little play in the driving shaft, but this is not a malfunction.

CAUTION: Exact torque should be verified with a torque wrench for precise limits as the screw can be damaged.

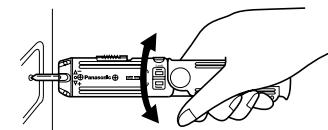

C Main switch (ON/OFF)

Push the upper half of the switch for forward (⌚) rotation, or the lower half for reverse (⌚) rotation.

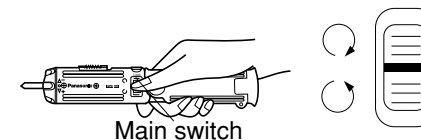

D Speed selector switch

To suit the application of this tool, two different rotational speeds are available. Depending upon use, either the high or low speed should be selected.

LOW	200min ⁻¹ (rpm)	strong torque
HIGH	400min ⁻¹ (rpm)	less torque

CAUTION: Check rotational speed selection before operating this tool.

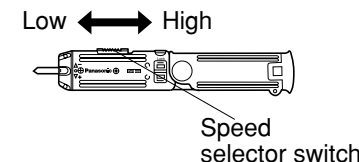

E Main switch lock

After use, set the main switch lock at the lock position to prevent accidental operation.

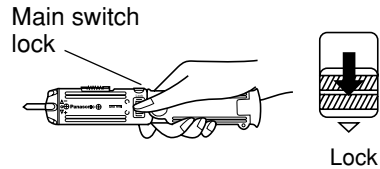

F Battery pack (EY9021)

CAUTION

When you charge the battery pack for the first time, or after prolonged storage, charge it for about 24 hours to bring the battery up to full capacity.

1. Press the battery pack release buttons **G** on both sides and pull the pack away from the tool.
2. Charge the battery pack using the battery charger.
3. After the charging has been completed, remove the battery pack from the charger and connect it to the tool. Disconnect the charger from the power source when not in use.

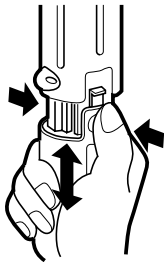

Battery Pack Life

The rechargeable batteries have a limited life. If the operation time becomes extremely short after recharging, replace the battery with a new one.

Note: Use under extremely hot or cold conditions will reduce operation capacity per charge.

G Battery pack release button

H Battery charger (EY0225)

1. Plug the charger into an AC outlet.
NOTE: Sparks may be produced when the plug is inserted into the AC power supply, but this is not a problem in terms of safety.
2. Insert the battery pack firmly into the charger.

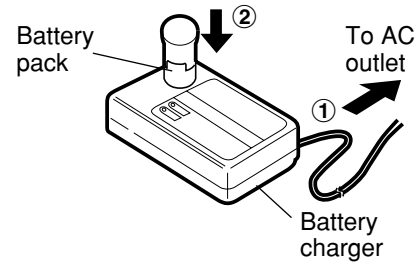

3. During charging, the charging lamp will be lit. When charging is completed, an internal electronic switch will automatically be triggered to prevent overcharging.
 - Charging will not start if the battery pack is warm (for example, immediately after heavy-duty operation). The orange standby lamp will be lit until the battery cools down. Charging will then begin automatically.
4. When charging is completed, the charging lamp will start flashing rapidly.
5. If a fully charged battery pack is inserted into the charger again, the charging lamp may light up and then flash slowly. After several minutes, the charging lamp may flash quickly to indicate the charging is completed.
6. If the charging lamp does not light immediately after the charger is plugged in, or if after the standard charging time the lamp does not go off, consult an authorized dealer.

NOTE: • When a cold battery (of about 5°C or less) is to be charged in a warm room, leave the battery in the room for at least one hour and charge it when it has warmed up to room temperature. (Failing to do so may result in

less than a full charge.)

- Cool down the charger when charging more than two battery packs consecutively.

CAUTION: • Do not use power source from an engine generator.

LAMP INDICATIONS

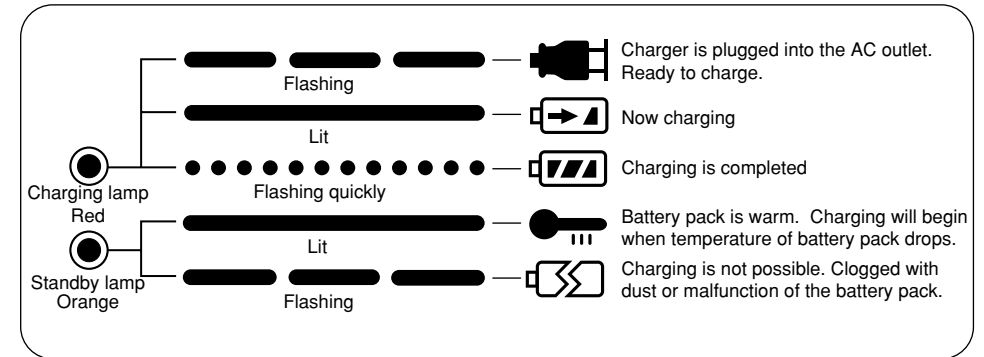

I #1 Philips bit

J Slotted head bit

K #2 Philips bit

Maintenance

Use only a dry, soft cloth for wiping the unit. Do not use a damp cloth, thinner, benzene, or other volatile solvents for cleaning.

BATTERY RECYCLING

ATTENTION:

A nickel cadmium battery that is recyclable powers the product you have purchased. At the end of its useful life, under various state and local laws, it is illegal to dispose of this battery into your municipal waste stream.

Please call 1-800-8-BATTERY for information on how to recycle this battery.



SPECIFICATIONS

CORDLESS DRILL & DRIVER (EY6220)

Motor	DC Motor 2.4 V
No load speed	LOW: 200 min ⁻¹ (rpm) HIGH: 400 min ⁻¹ (rpm)
Hexagonal driving shaft	6.35 mm, (1/4") across flats
Maximum drilling dia. for metal	2 mm (5/64")
Maximum torque	LOW: 2.9 Nm (30 kg-cm, 26 in.lbs) HIGH: 1.5 Nm (15 kg-cm, 13 in.lbs)
Maximum clutch torque	2.0 Nm (20 kg-cm, 17.5 in.lbs) at 5 position
Overall length	239 mm (9-3/8")
Weight (with battery pack)	0.4 kg (0.9 lbs)

BATTERY PACK (EY9221)

Storage battery	Ni-MH battery
Battery voltage	2.4 V DC (1.2 V × 2 cells)

BATTERY CHARGER (EY0L11)

Charging time	45 min
Mass (Weight)	0.6 kg (1.54 lbs)

NOTE: For applicable battery packs to this charger, see the label on the charger or the latest general catalog.